docit™

1	introduction
2	rails
3	work stations
4	architectural elements / accessories
5	power delivery
6	primary & secondary power delivery systems & cable management
7	data & communication distribution
8	working models / layout examples
9	pods & linear
10	linear (perpendicular)
11	linear (parallel)
12	configuration example A
14	configuration example B
16	configuration example C
18	configuration example D

Conceptually, Doc-It represents an innovative and effective system for addressing power and data communication distribution in free standing open office environments. As a tool, it bridges mobile, or stationary freestanding furniture with power delivery.

Doc-It is best utilized when installed between work stations in such a way that it's distribution services can be accessed from both sides. The most flexible application, able to accommodate furniture densification needs is a straight linear configuration.

what is doc-it?

Doc-It is a desk height horizontal rail with an integrated data/communication trough, with off-module structural support at the bottom and off-module accessories at the top.

Doc-It provides a nonpermanent skeleton, assisting in creating a grid for placement (anchoring/docking) of freestanding work stations. It addresses territorial issues as it becomes a tool for implementing order within the freestanding landscape. It enables easy reconfiguration/densification while minimizing the down-time.

In the context of viceversa mobile furniture, Doc-It works in conjunction with highly flexible, multifunctional components - from height adjustable primary work surfaces, mobile auxiliary table, versatile storage solutions, mobile screens to accessories. Visually coordinated design concepts and details of Doc-It work in harmony with viceversa - providing a complete open office solution. A linear assembly of interconnected horizontal rails (with multiple power and data/communication terminal points) divides a given room into zones. The zones are further divided by individual work stations along both sides of the Doc-It rail. The work stations could be longitudinally along the trunk or rotated and docked for easy densification. Because the power system and data/comm. cables with terminals remain in place, within the Doc-It rail, office equipment could be plugged to existing terminal points at the new locations, without the need for an electrician or IT crew, thus minimizing the down time.

A customer interested in Doc-It will probably be a progressive thinker, sensitive to long term facility issues. Concerned with cost of ownership - evaluating furniture from an investment perspective. The organization has a need to rearrange work environments to suit specific short and medium range projects with varying number of team members. Technology is an integral part of this organization and furniture is also viewed as one of the tools increasing productivity in general office and team centers.

The customer is interested in managing change, technology and flexible teams as well as simplifying management of furniture inventory through fewer universal components that do more. There is a need to address ergonomics, ventilation, improve quality of office environment as well as the need to introduce openness, teamwork, or to provide everyone with a view and access to a daylight. There is also a clearly identified desire to project a progressive image of a dynamic, forward thinking organization that provides it's valued employees with a modern work environment.

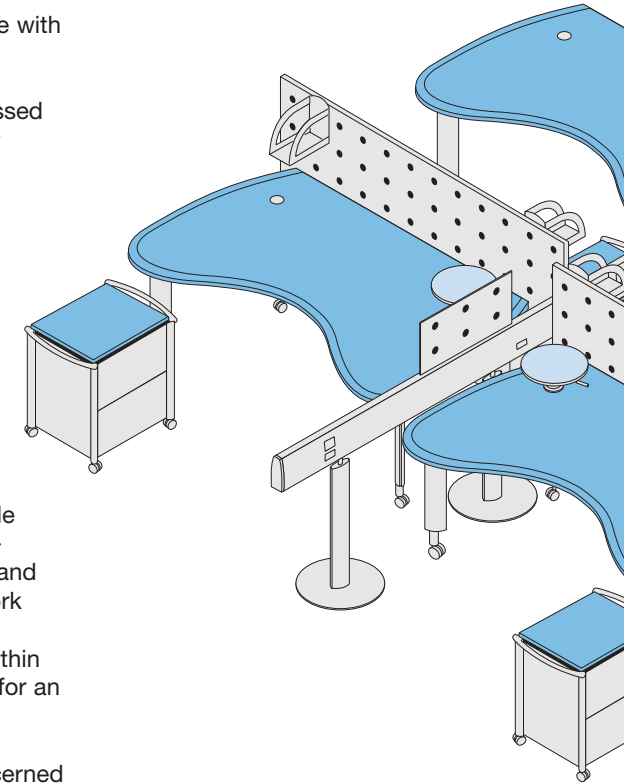

application guide

rails

Multiple assemblies of interconnected horizontal rails divide a given room into zones.

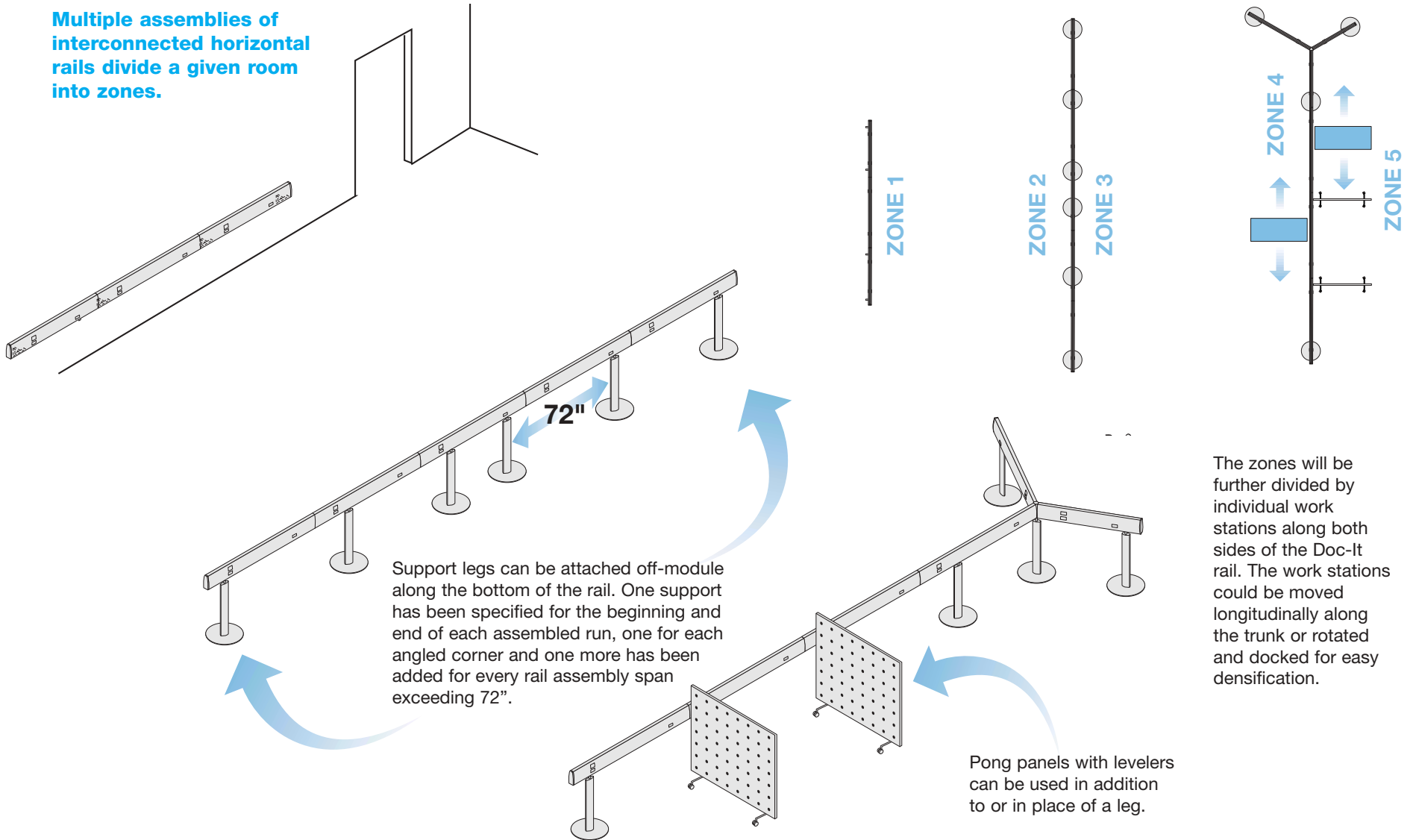

The zones will be further divided by individual work stations along both sides of the Doc-It rail. The work stations could be moved longitudinally along the trunk or rotated and docked for easy densification.

Example below illustrates how zones along Doc-It rail are divided by individual work stations. The work stations could be moved longitudinally along the trunk or rotated and docked for easy densification.

Study work flow, team habits and individual needs to establish components forming individual work stations and their location to facilitate work information flow and team habits.

Mobile storage components organize files and can be shared between users.

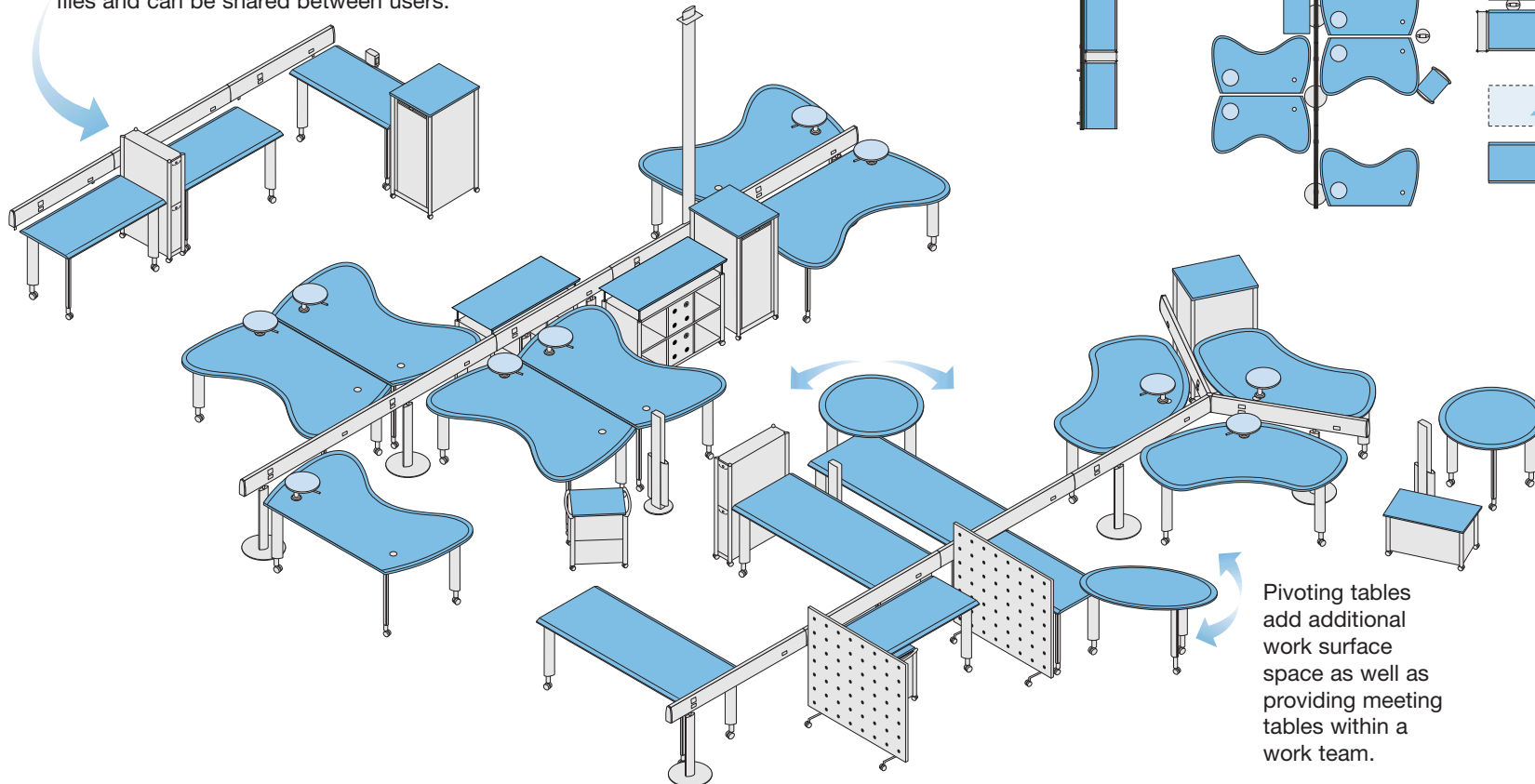

Workflow, team habits and individual needs establish the necessary components that form each workstation.

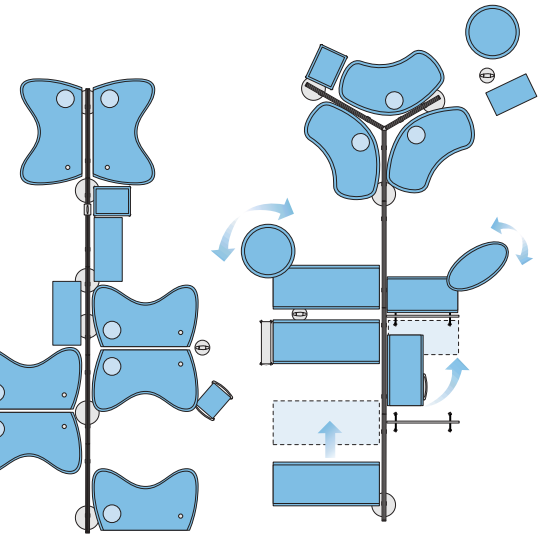

Pivoting tables add additional work surface space as well as providing meeting tables within a work team.

architectural elements / accessories

Architectural elements, such as table mounted or free standing Pong panel and memo screens divide space and add functionality to work stations.

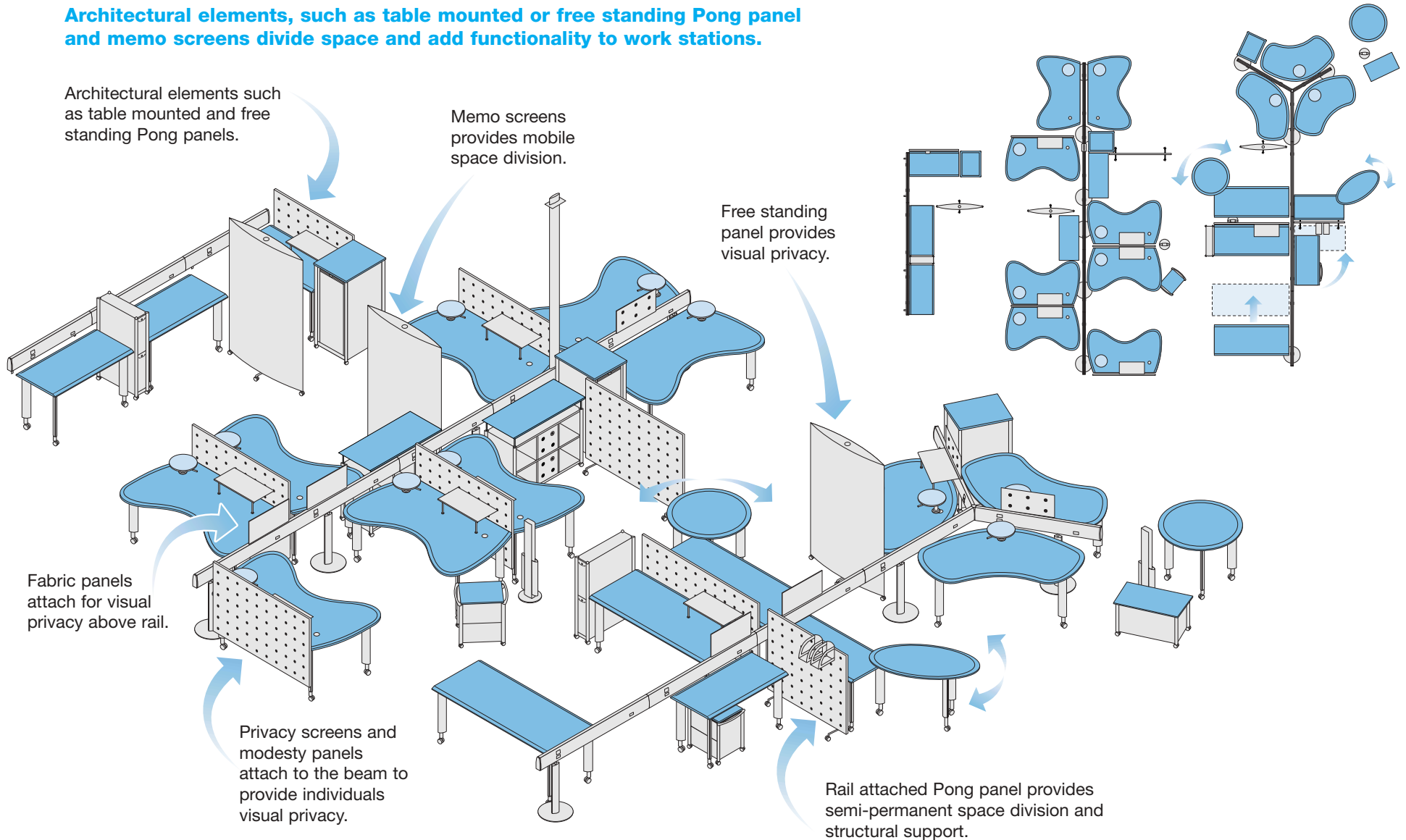

Architectural elements such as table mounted and free standing Pong panels.

Memo screens provides mobile space division.

Free standing panel provides visual privacy.

Fabric panels attach for visual privacy above rail.

Privacy screens and modesty panels attach to the beam to provide individuals visual privacy.

Rail attached Pong panel provides semi-permanent space division and structural support.

Primary distribution: Note three ways of bringing power to Doc-It:

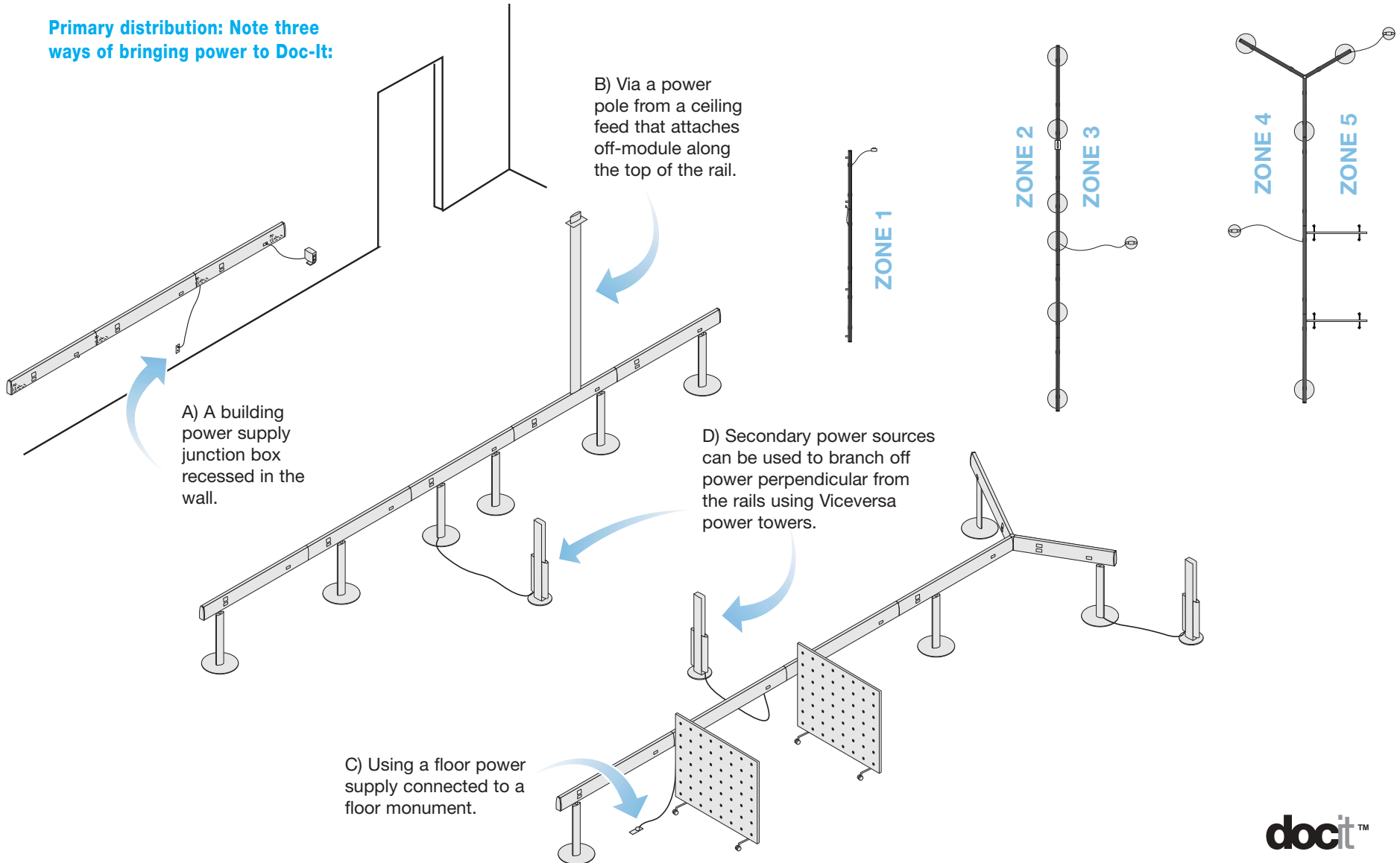

primary & secondary power delivery systems & cable management

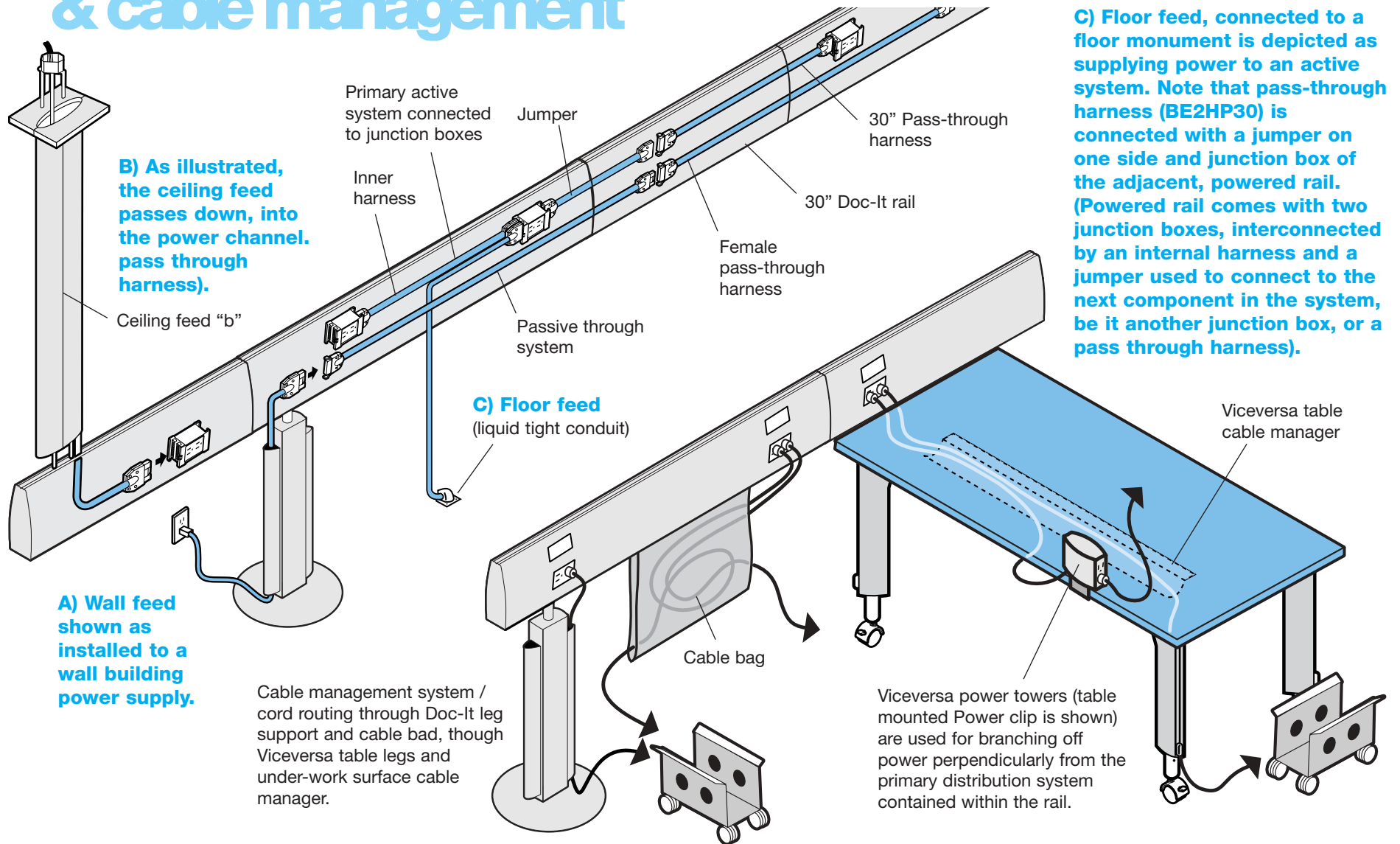

B) As illustrated, the ceiling feed passes down, into the power channel, pass through harness).

Ceiling feed "b"

A) Wall feed shown as installed to a wall building power supply.

Cable management system / cord routing through Doc-It leg support and cable bad, though Viceversa table legs and under-work surface cable manager.

C) Floor feed (liquid tight conduit)

C) Floor feed, connected to a floor monument is depicted as supplying power to an active system. Note that pass-through harness (BE2HP30) is connected with a jumper on one side and junction box of the adjacent, powered rail. (Powered rail comes with two junction boxes, interconnected by an internal harness and a jumper used to connect to the next component in the system, be it another junction box, or a pass through harness).

Viceversa power towers (table mounted Power clip is shown) are used for branching off power perpendicularly from the primary distribution system contained within the rail.

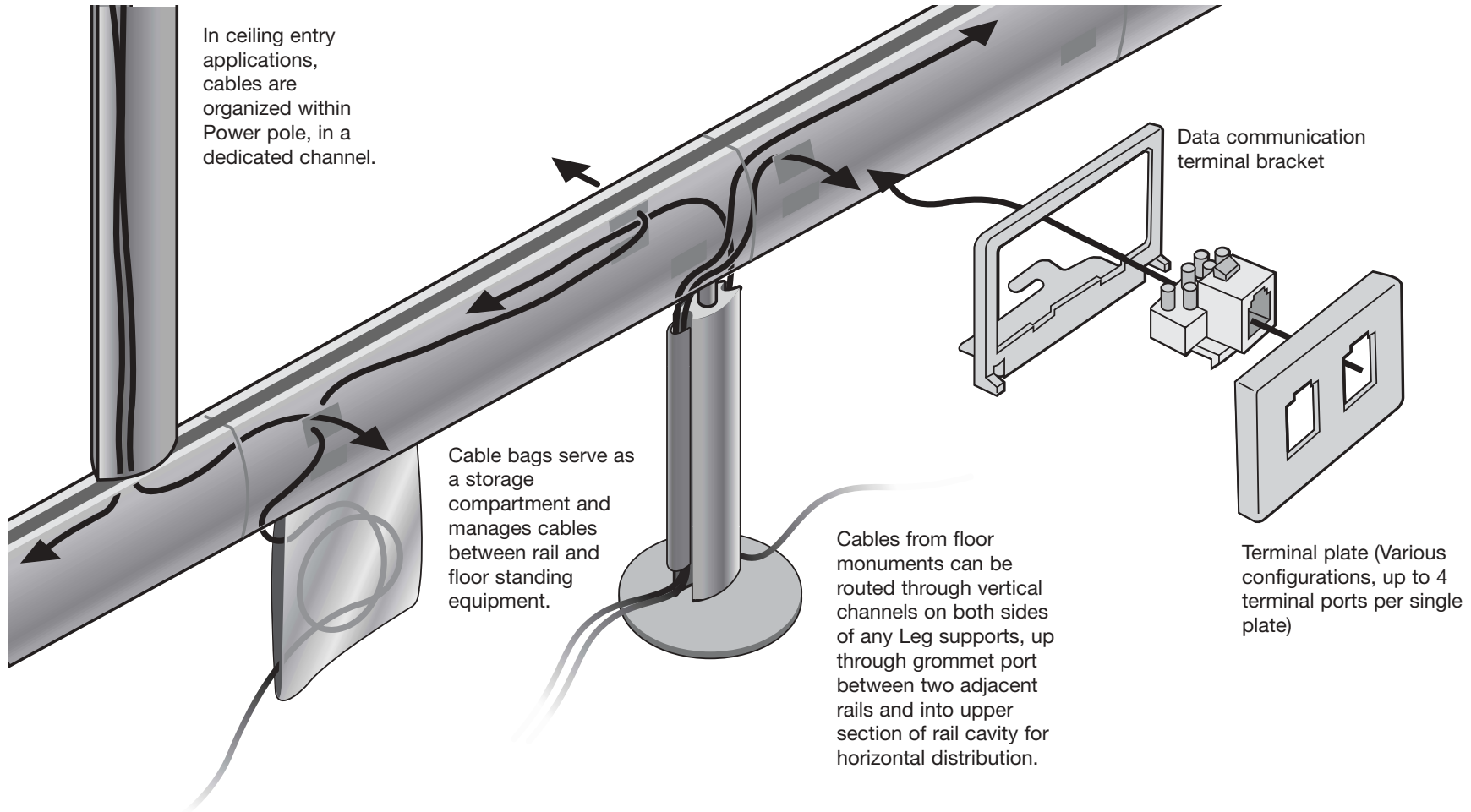

Once at the rail level, cable's horizontal distribution takes place behind rail covers in the upper section of the rail cavity, which also houses injection molded lay-in cable organizers and metal data/comm. terminal brackets.

working models / layout examples

A) PODS Pods represent the simplest form of a Doc-it application. Once the primary work station building blocks (work surface, seating, task and office supplies organizers), this “typical” can be repetitively dropped into the office layout.

Advantages of furnishing office environments in this fashion is speed and simplicity of specifying, but mainly commonality of used components, which simplifies inventory control, maintenance / replacement and reconfiguration.

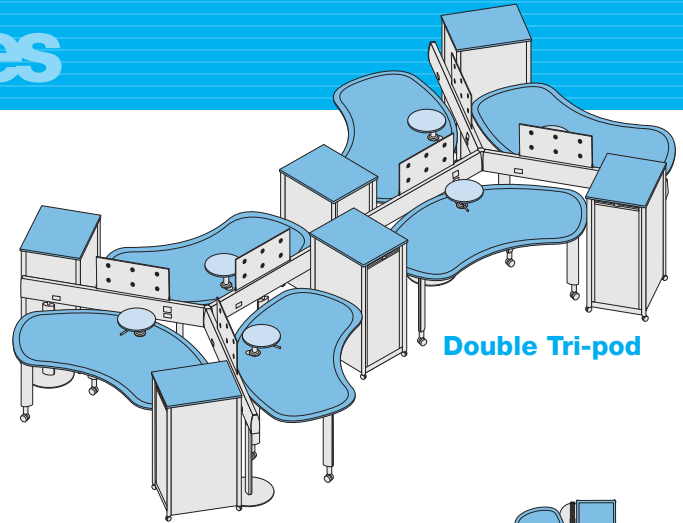

Double Tri-pod

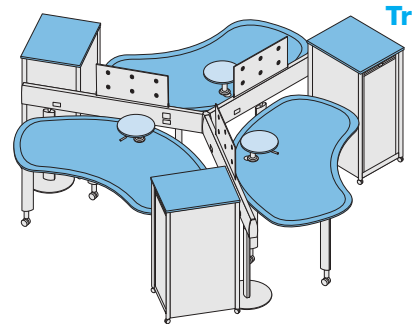

Tri-pod

Multiples

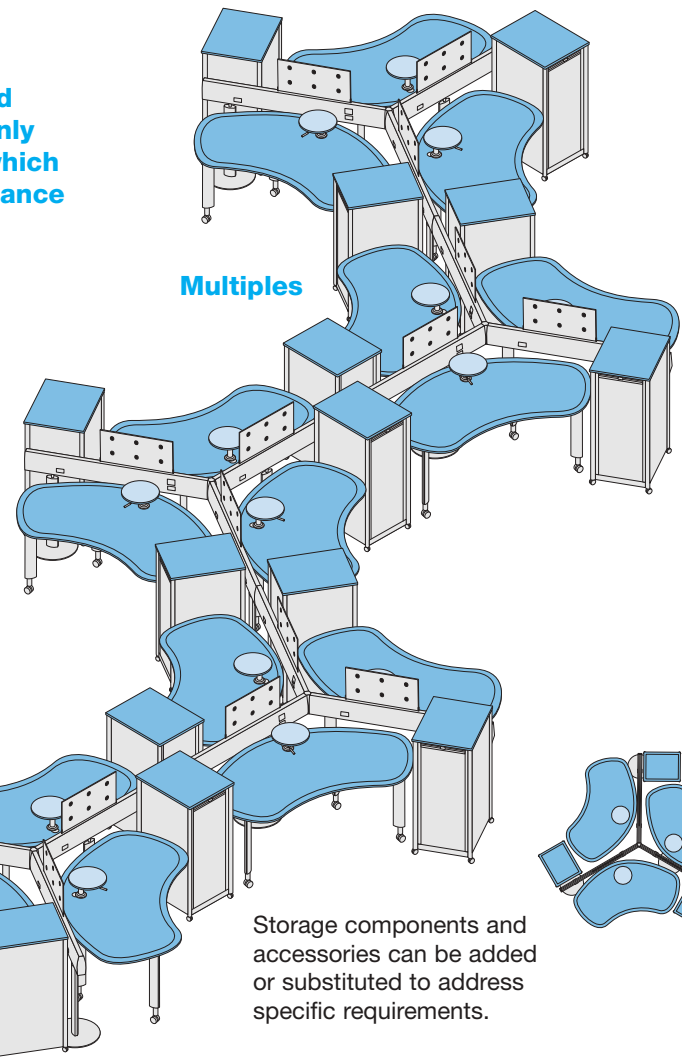

Examples illustrated are based on a single length of Doc-It powered rail, arranged into mainly 120° configurations. Work table is Viceversa Cloud and storage is Viceversa 3H. Metal privacy screens were added to the rails to cover rear of monitors facing co-workers.

Storage components and accessories can be added or substituted to address specific requirements.

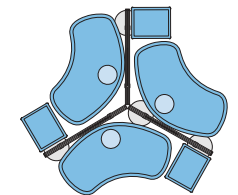

Adding additional rails, power and data cables will allow more flexibility to this configuration when increased capacity is required.

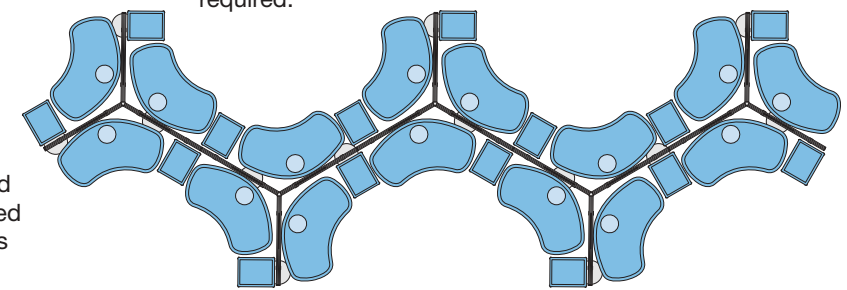
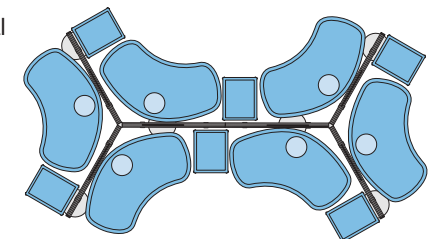

spring 2003

This configuration builds upon advantages presented in the previous example of a pod specification (simplicity of specification, inventory control and maintenance / replacement through commonality of used components) and combines it with advantages of linear lay-outs which offer greatest amount of flexibility for a quick reconfiguration or future growth.

This configuration could be used as a general office of a small business and would also be suitable for departments with varying degree of work [...word cut off...] real estate and storage requirement as well as varying level of desired team interaction (substitute / add storage and accessories to address specific requirements).

Work tables: Viceversa Cloud, Dog bone w/ Pong; storage is Viceversa 3H, Toto, Multi, Pong selves and Binder bins. Acrylic privacy screens were added to further define individual territories without blocking off light.

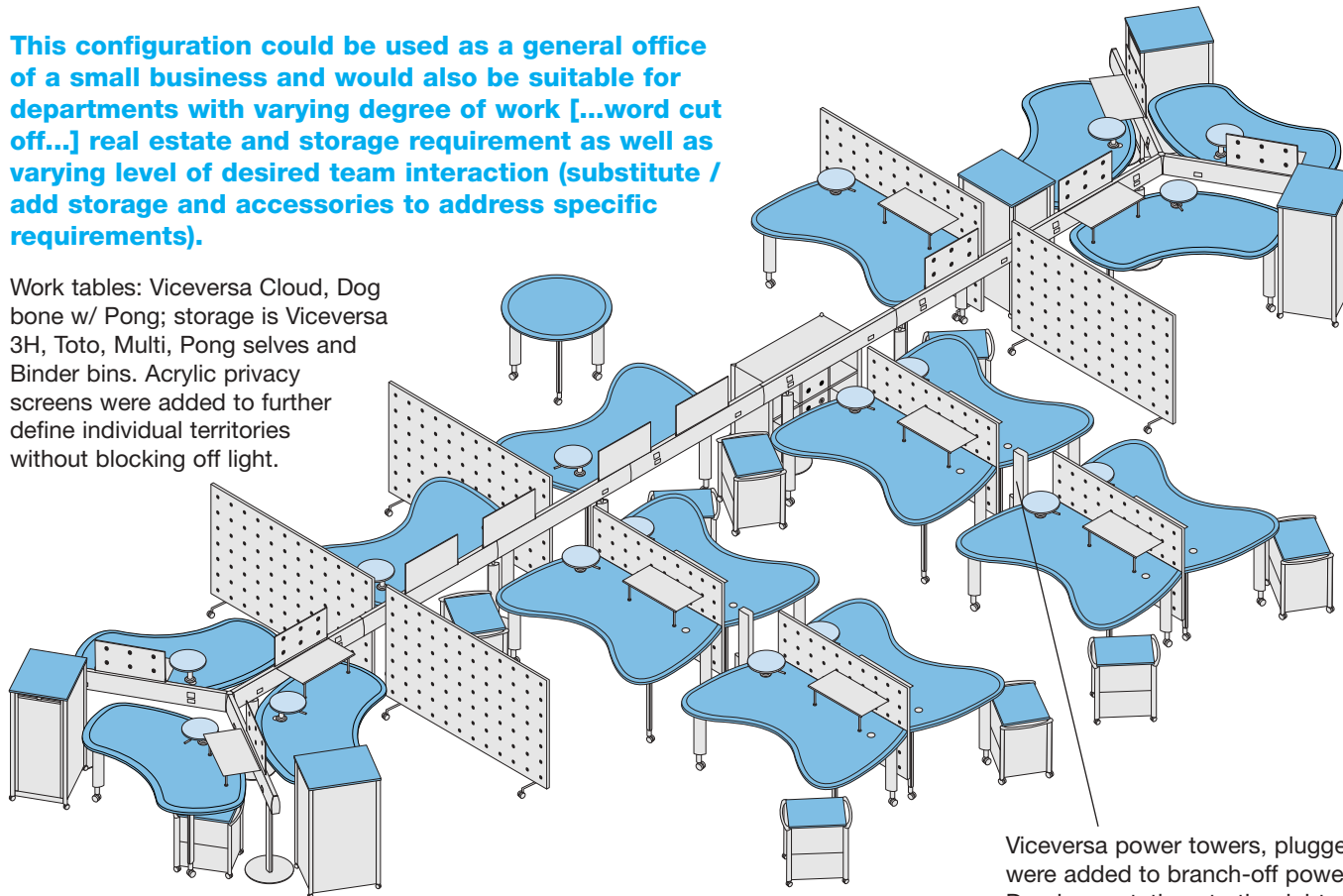

Examples illustrated below are based on a single length of Doc-It powered rail, arranged into a combination of 180° and 120° configurations.

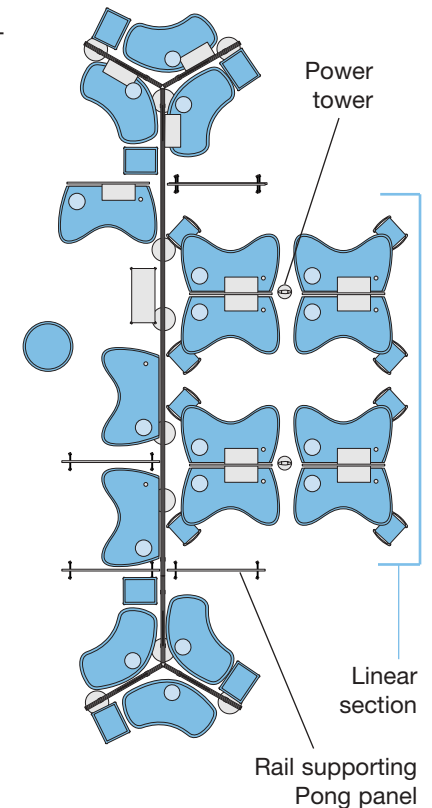

Viceversa power towers, plugged to Doc-It rail, were added to branch-off power to supply eight Dog bone stations to the right of the rail.

linear (perpendicular)

Linear configurations of the Doc-It rail maximizes the potential of the product - offering greatest amount flexibility for a quick reconfiguration, densification and future growth. The rail assembly could be built with identical length-modules, thus simplifying specification, inventory control and maintenance / replacement through commonality of used components.

Examples illustrated below are based on a single length of Doc-It powered rail, arranged into a linear, 180° configuration.

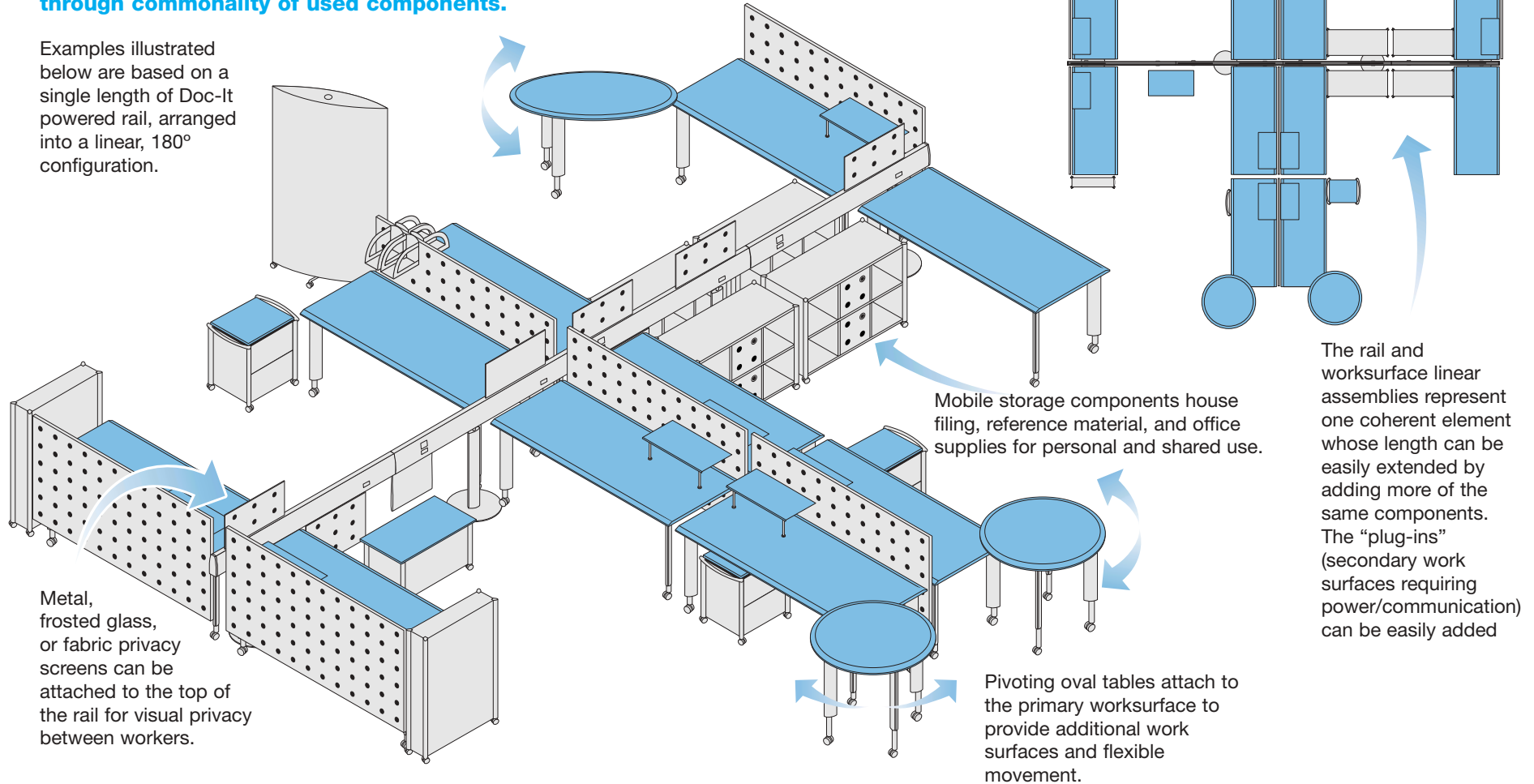

Metal, frosted glass, or fabric privacy screens can be attached to the top of the rail for visual privacy between workers.

Mobile storage components house filing, reference material, and office supplies for personal and shared use.

Pivoting oval tables attach to the primary worksurface to provide additional work surfaces and flexible movement.

The rail and worksurface linear assemblies represent one coherent element whose length can be easily extended by adding more of the same components. The “plug-ins” (secondary work surfaces requiring power/communication) can be easily added

While the previous example had work surfaces configured perpendicularly to the rail, the illustration below depicts primary work surfaces installed parallel, along both sides of the rail. This concept illustrates that worksurfaces and rails form linear assemblies on the secondary tables, accessories and storage compounds forming the function of the workstation. This concept suggests that the primary work surface followed the same guiding principle used for linear rail, and storage, secondary work surfaces and accessories became “plug-in” tools for customizing work stations.

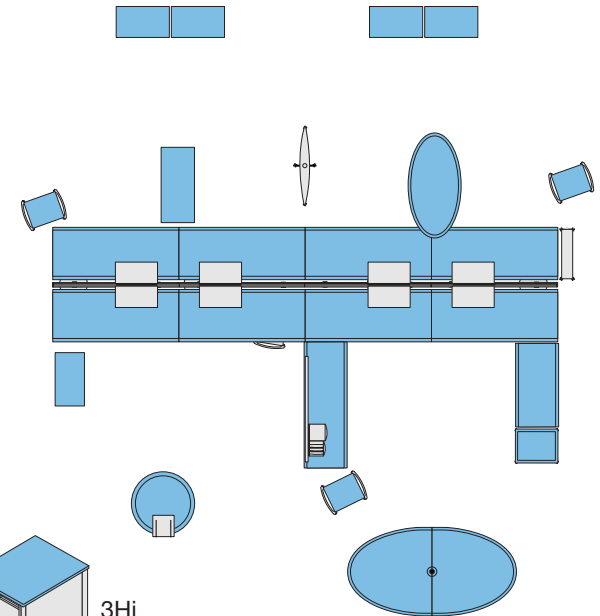
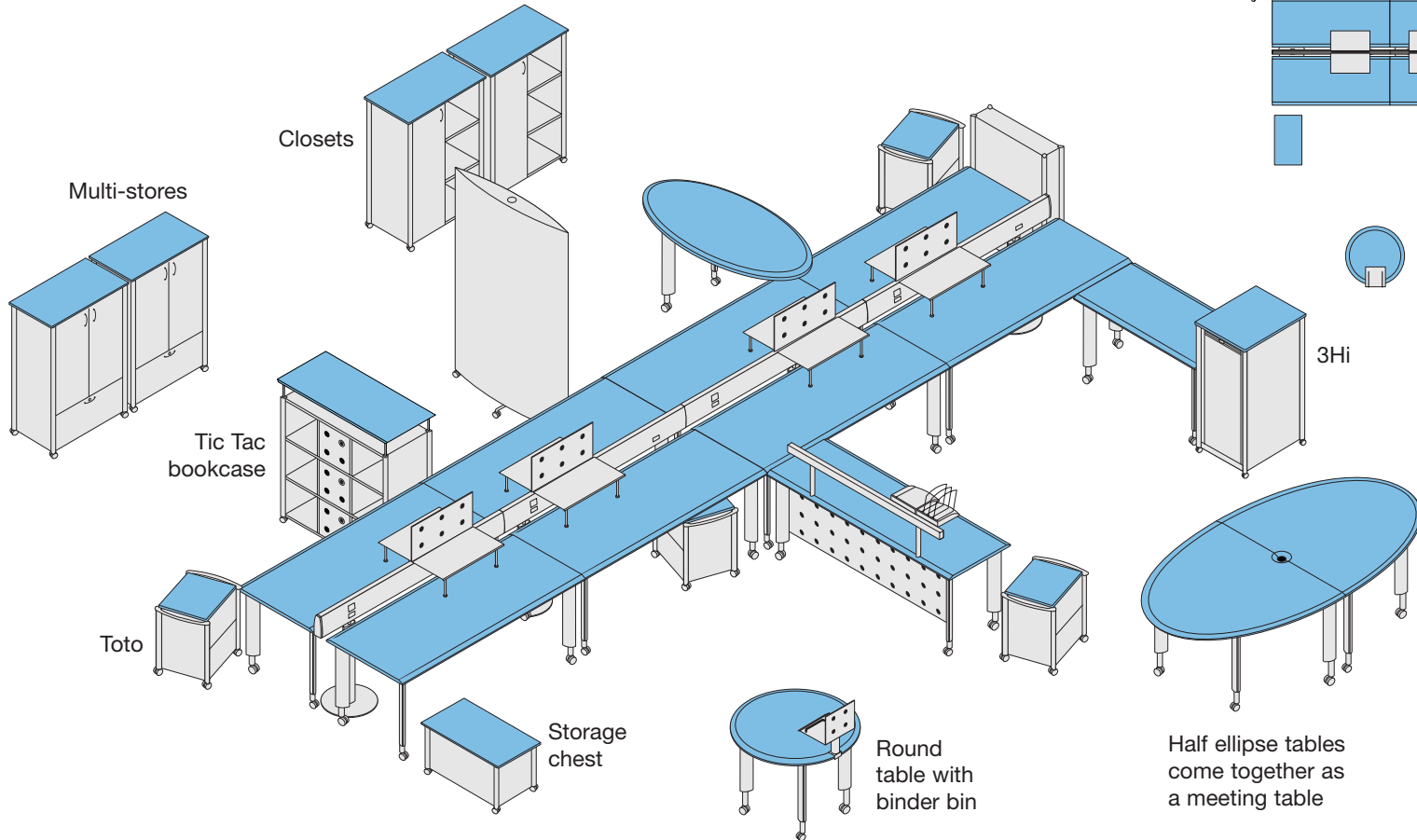

Examples illustrated show the rail assembly and both parallel runs of work surfaces built with identical, 72" long components, thus simplifying specification, inventory control and service through commonality of used components.

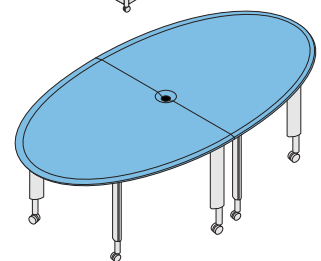

Half ellipse tables come together as a meeting table

configuration example A

1

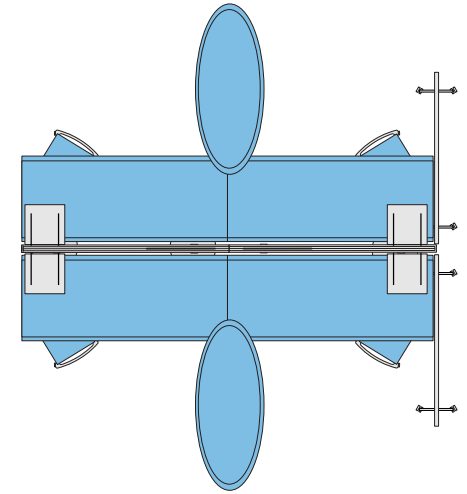
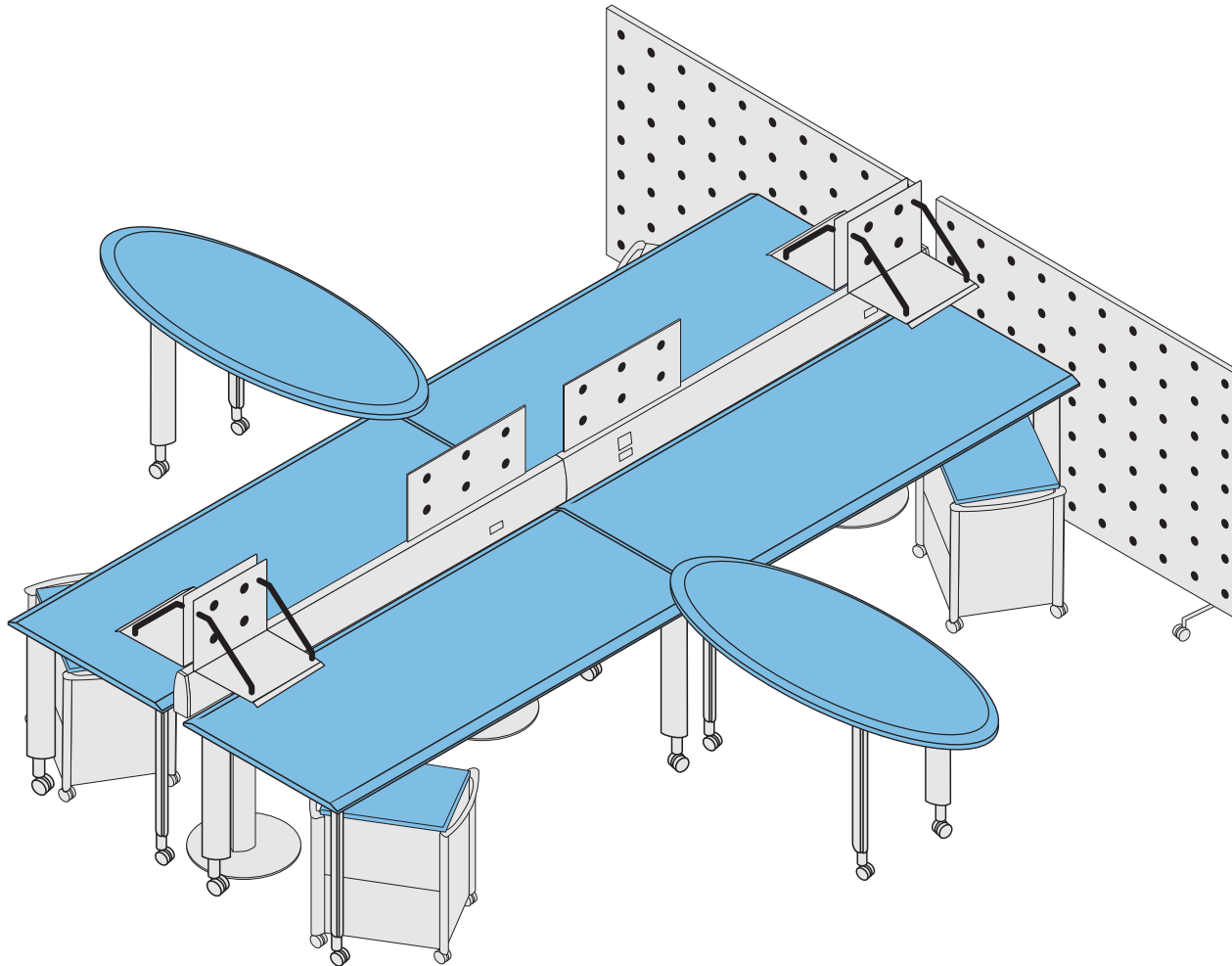

2

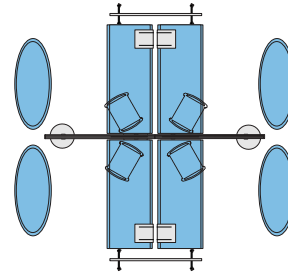
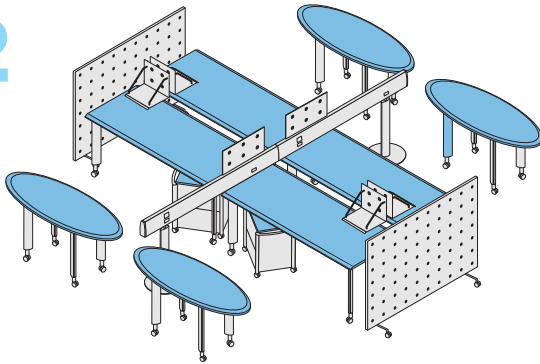

3

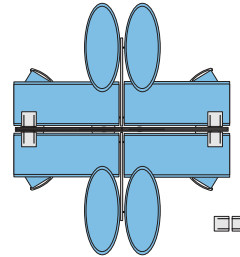
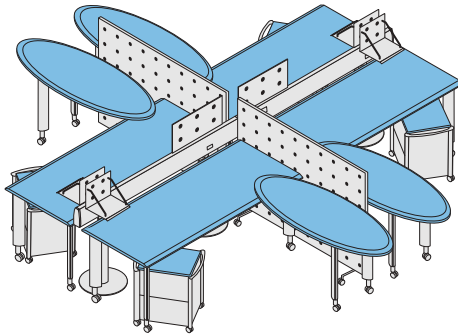

4

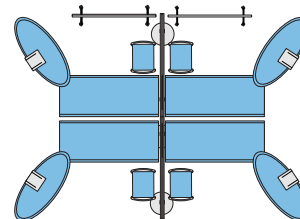
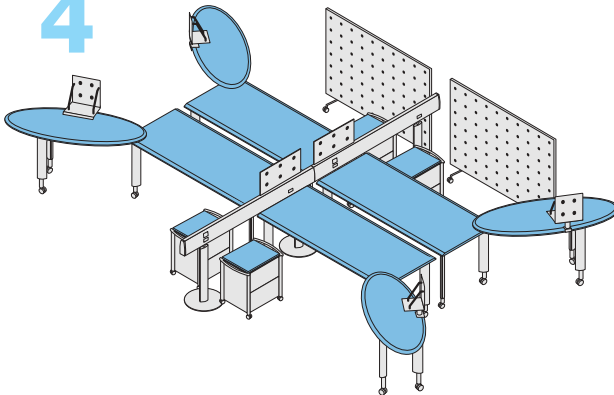

components

pong

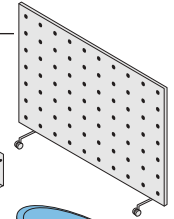

binder bin



oval

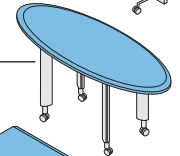

rectangular

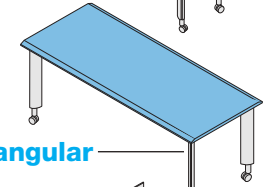

privacy screen



rail

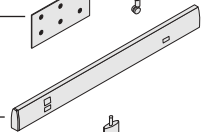

rail support

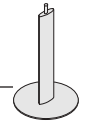

toto

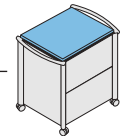

configuration example B

1

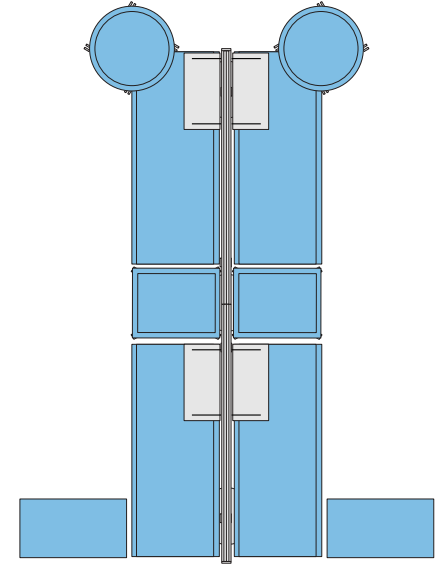
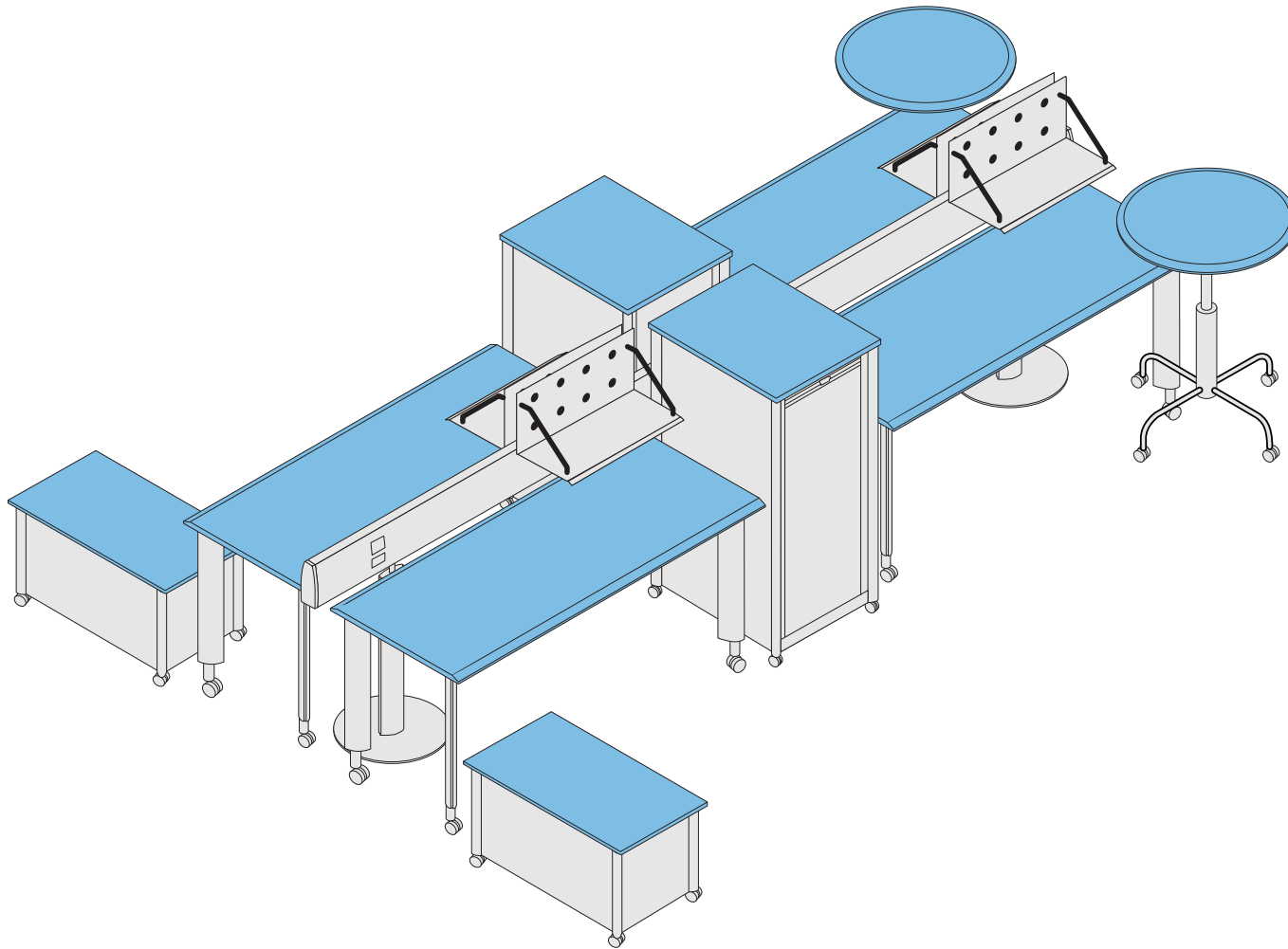

2

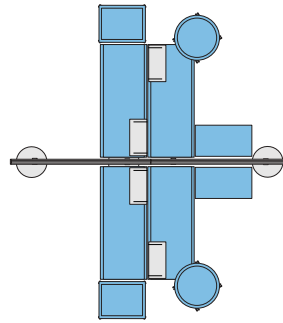
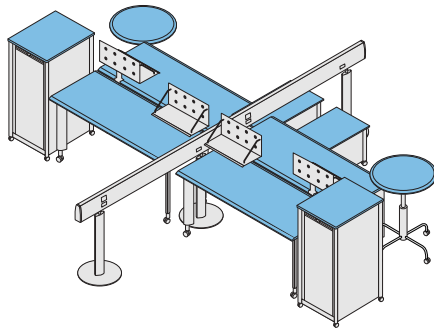

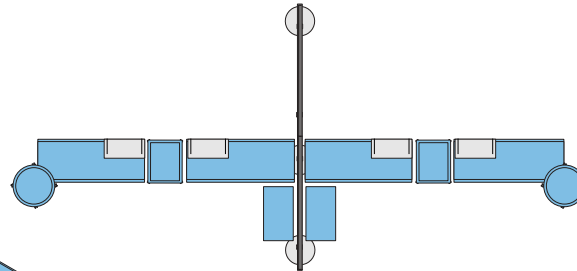
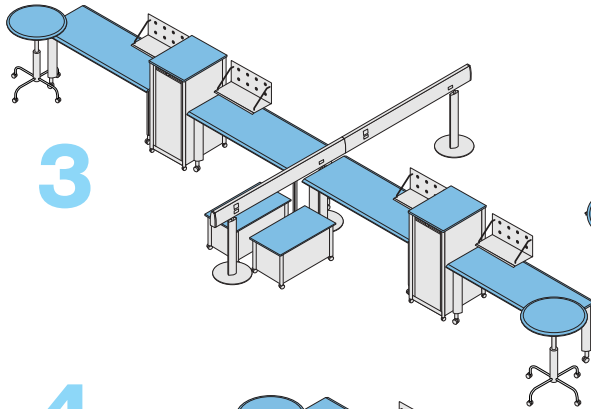

3

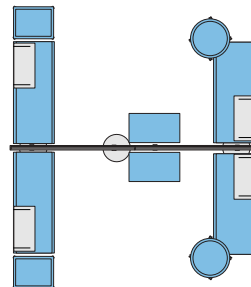
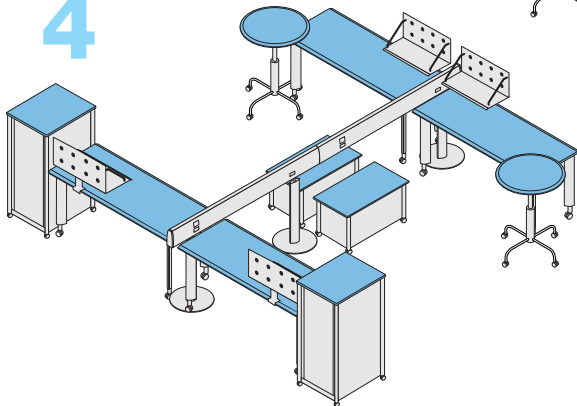

4

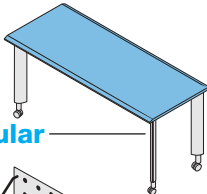

components

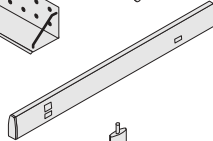
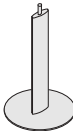
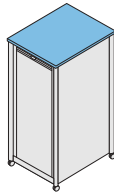
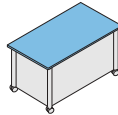
- gobie** 
- rectangular** 
- binder shelf** 
- rail** 
- rail support** 
- 3hi** 
- storage chest** 

configuration example C

1

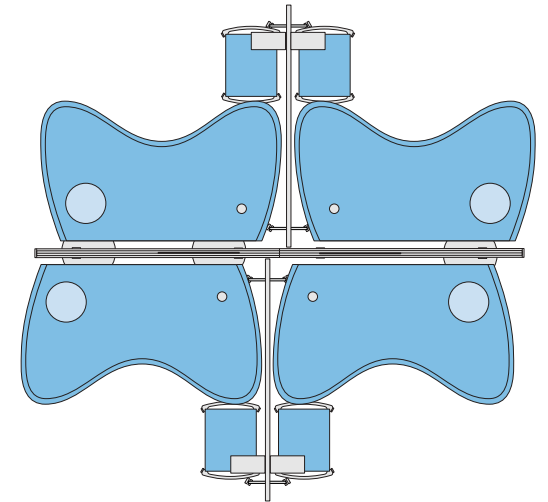
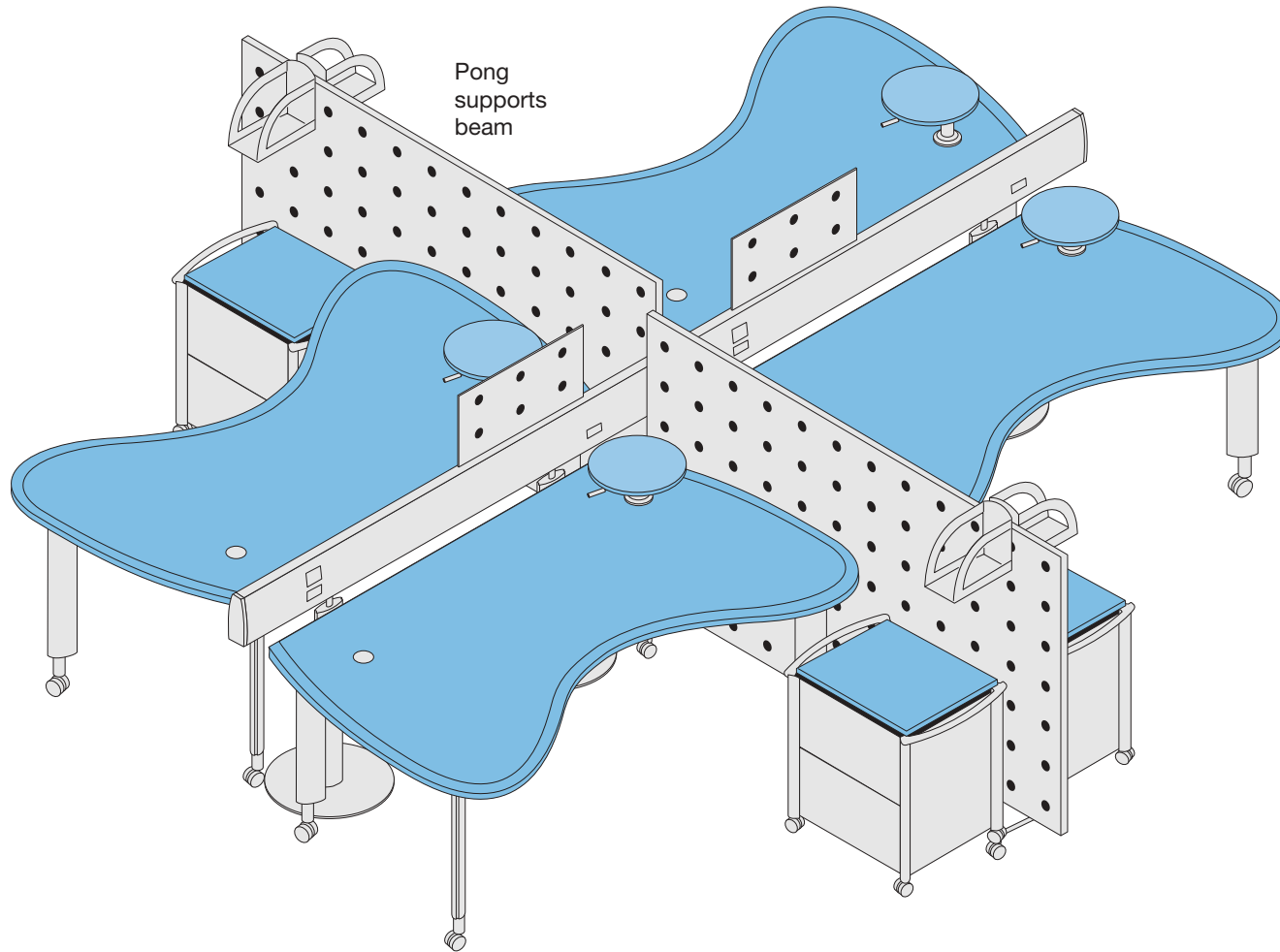

configuration example C

spring 2003

2

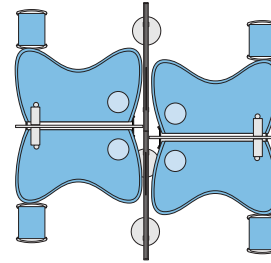
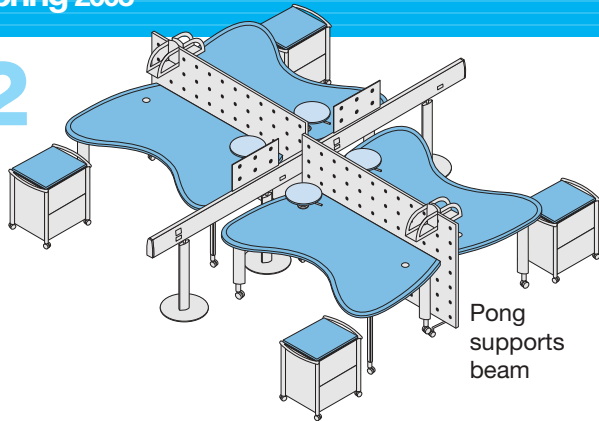

3

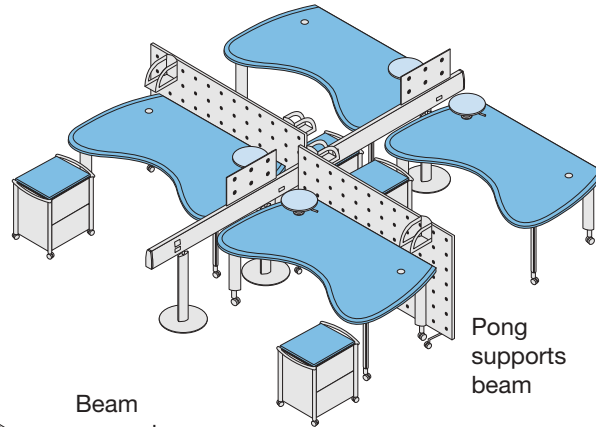
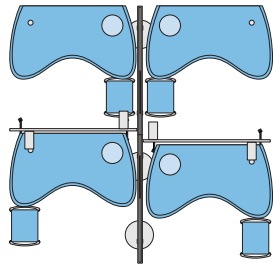

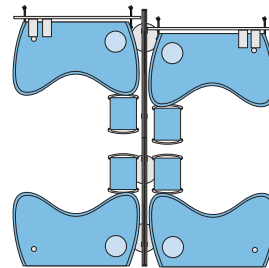
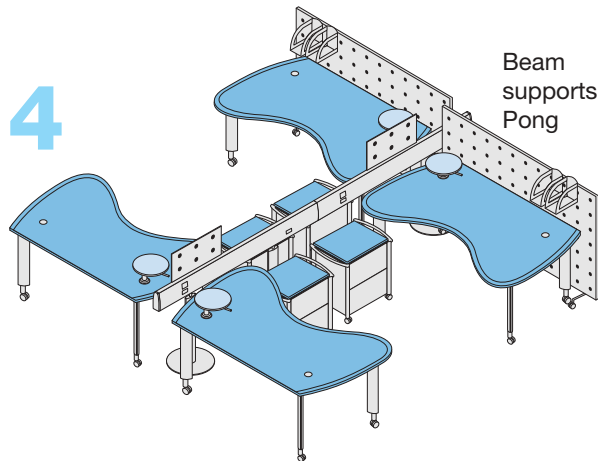

4

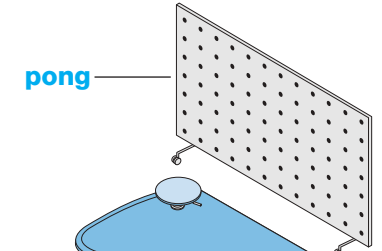

components

binder holder 



dog bone 

privacy screen 

rail 

rail support 

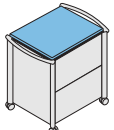
toto 

configuration example D

1

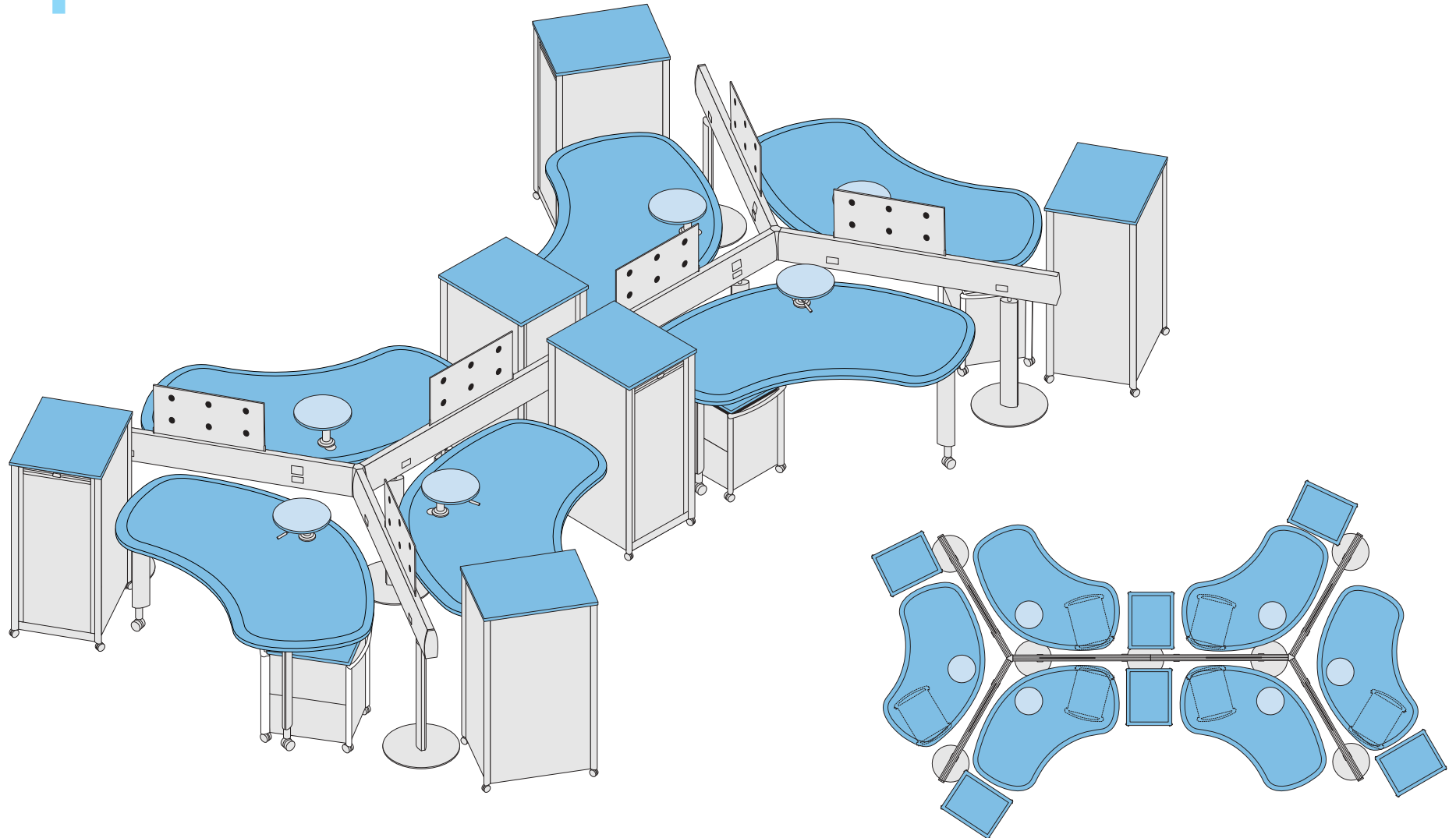

configuration example D

spring 2003

2

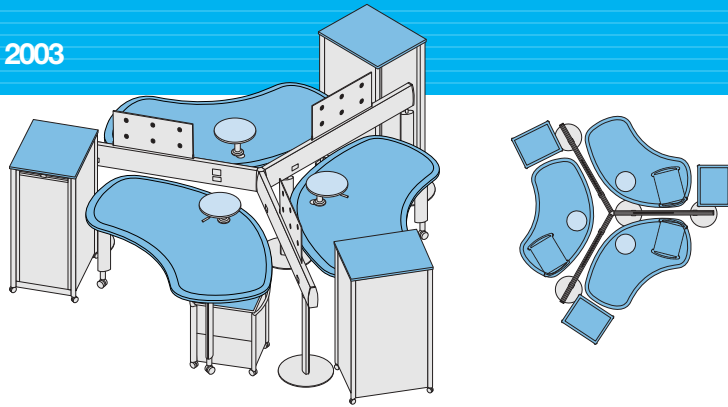

3

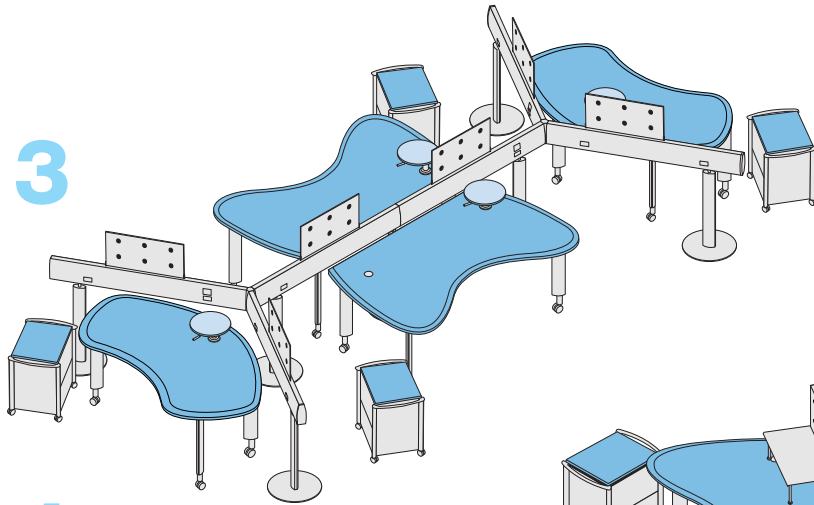

4

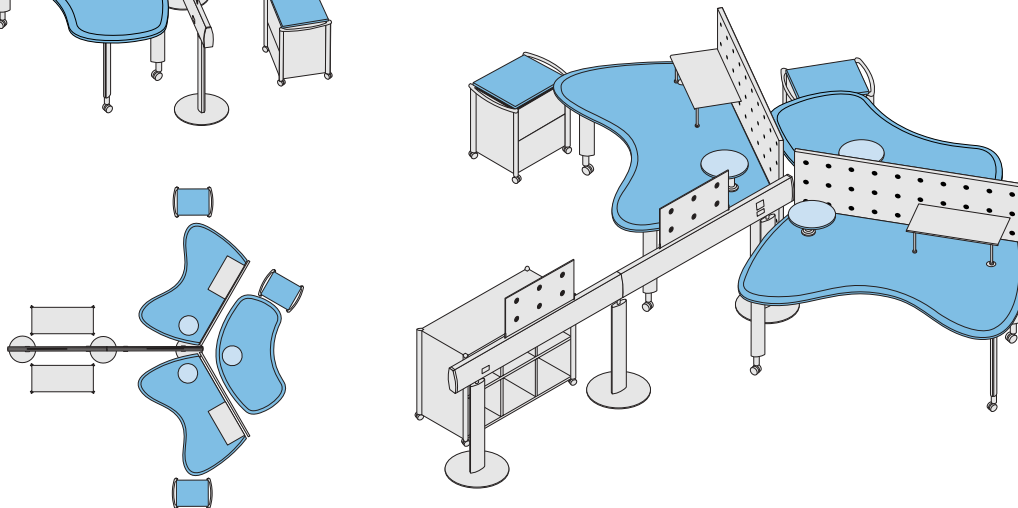

components

